

ENG 



# CATALOG

**N&N**®  
NADRATOWSKI

# P SERIES

N&N Nadratowski offers high quality column loaders and tippers for standard euro bins, dolavs, as well as other tanks on request. The column loaders can be fixed to the mixer, in a free-standing version (ground mounting) or in a mobile version as a loading system for other equipment and applications. All of our loading systems have the CE mark.

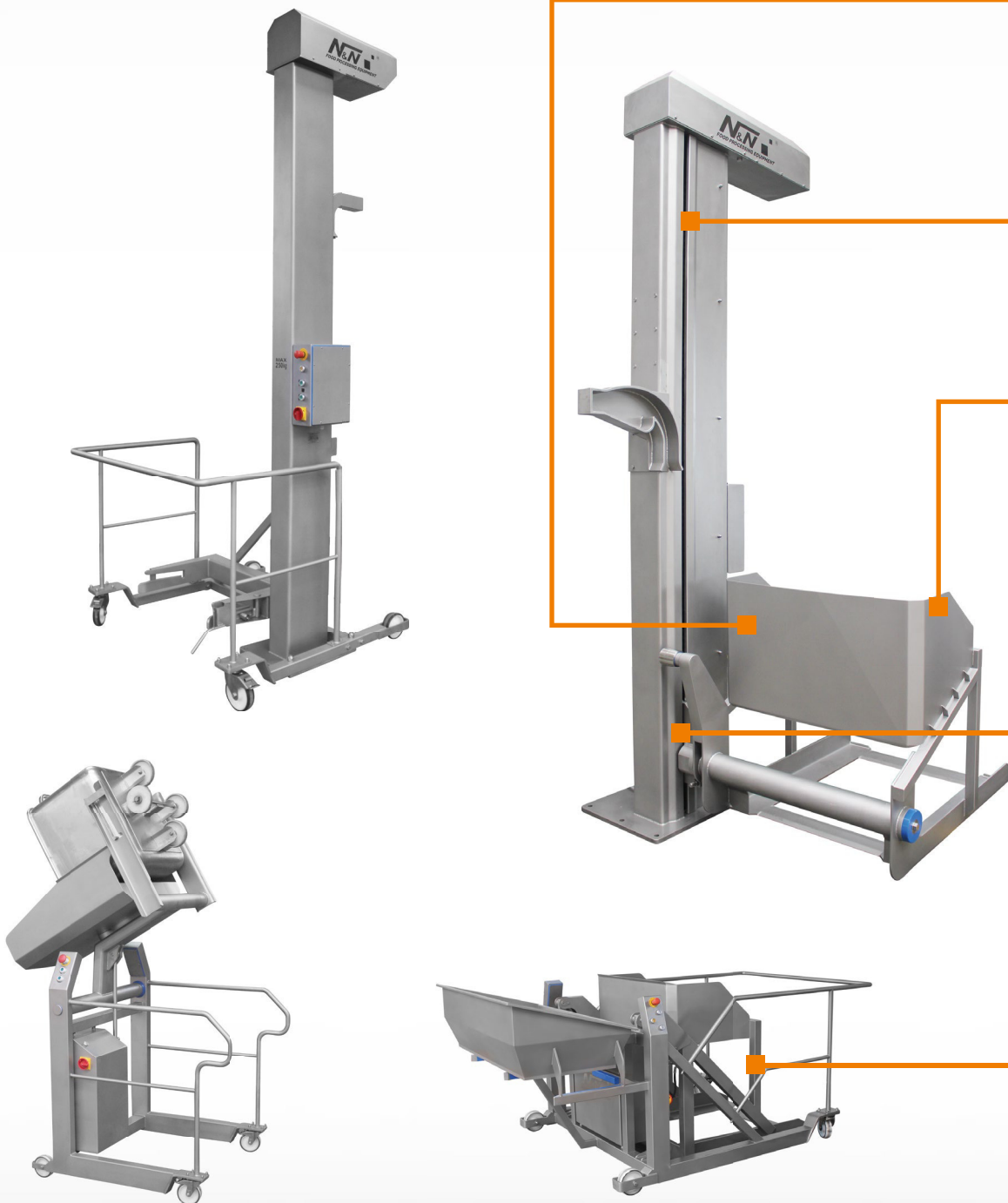

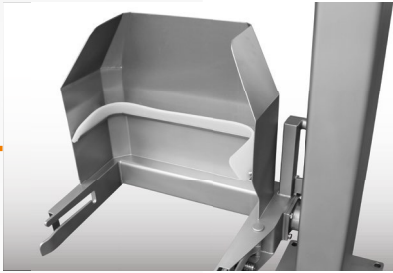

## HIGHEST QUALITY OF WORKMANSHIP

The P-series loading systems are top-class aesthetics and workmanship, and their reliable and durable construction allows to enjoy reliable operation for many years.



## INDIVIDUAL GRIPPERS

Column loader, aside from the standard gripper of the DIN9797 euro bin, can be adapted to lift barrels, crates or other containers according to the customer's needs and requirements.



## INDIVIDUAL APPROACH

A wide range of additional accessories allows us to increase the range of applications for our elevators and tippers, for example by means of sealing jackets, pressure funnels or an additional strainer.

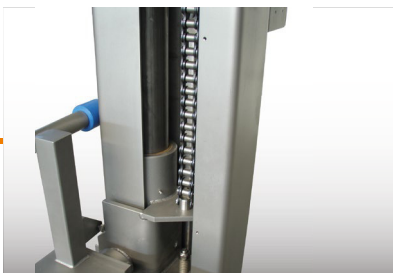

## SAFETY

N&N Nadratowski puts great emphasis on the safety and reliability of its equipment. Column loaders are equipped with a highly durable galvanized chain and a mechanical safety brake provides additional protection against falling of the trolley in the event of chain breakage.



## INDIVIDUAL SOLUTIONS

In order to meet the expectations of its customers, N&N Nadratowski is able to offer customized loading, unloading or handling solutions based on proven solutions.

# COLUMN AND SWING LOADERS

P

SWING LOADER MODEL [P]	PZ 3/250	PZ 3/1000
Maximum lifting capacity [kg]	380	1000
Column loader power [kW]	0,75	1,5
Fuse [A]	6	10
Voltage [V,Hz]	230,50 or 400,50	400,50
Net weight [kg]	186	475 (type height I)

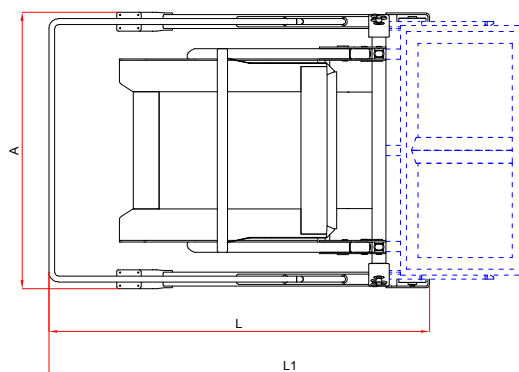
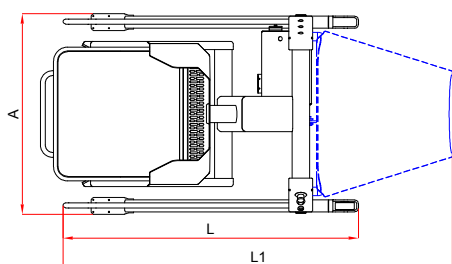
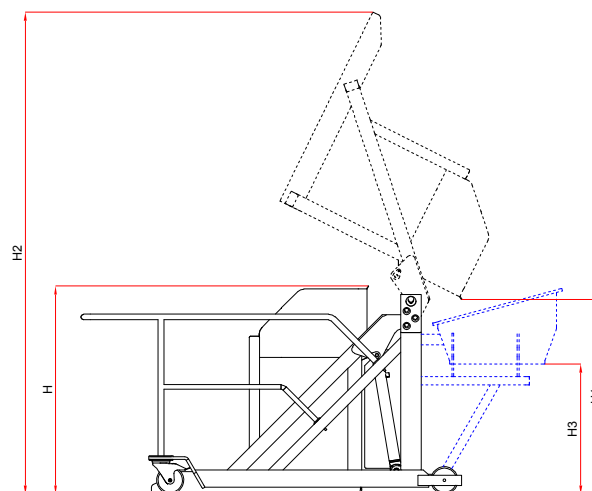
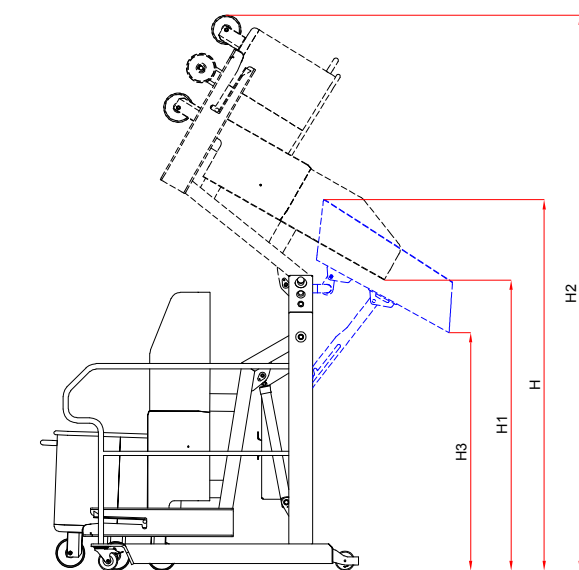

## PZ 3/250

## PZ 3/1000

TYPE HEIGHT	PZ 3/250	PZ 3/250 MV
H [cm]	129	189
H1 [cm]	118	148
H2 [cm]	240	283
H3 [cm]	-	110-133
L [cm]	130	151
L1 [cm]	-	198
A [cm]	103	103

TYPE HEIGHT	I	II	III
H [cm]	122	150	175
H1 [cm]	113	130	152
H2 [cm]	283	315	346
H3 [cm]	73	96	-
L [cm]	222	236	196
L1 [cm]	281	295	-
A [cm]	164	164	164